

HB 630 Sliding Door Lock

Please note these are primarily designed for 38mm doors or thicker.

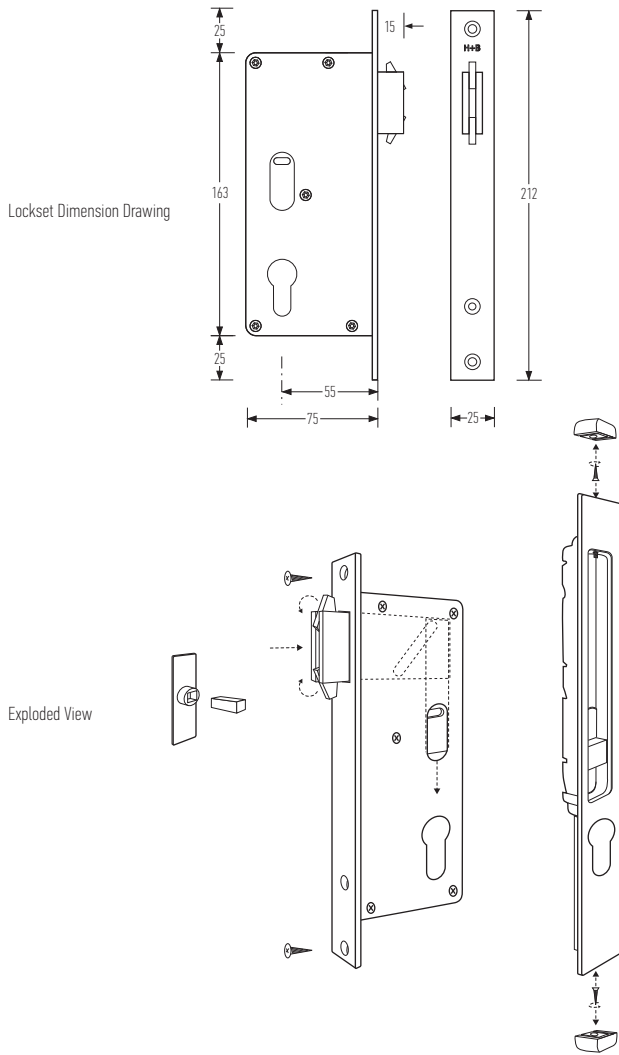

When installed with the snib slid down as far as possible (Fig. 1) the lock bolt and teeth will be retracted inside the body (Fig. 2). If the door is slid closed whilst the lock bolt is in the out/locked position (Fig. 3) you risk breakages to both the lock and the strike plate.

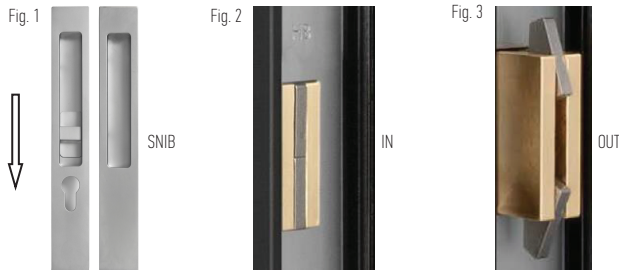

Once you have drawn your slider to its closed position in the frame, simply slide the snib up and the lock bolt and teeth will engage in the receiving strike. When using your key this will lock the snib in place. Please note the key cylinder does not drive the lock bolt itself but locks the snib in place acting similar to a dead bolt function. **THE LATCH SHOULD NEVER BE LEFT OUT WHEN PULLING YOUR SLIDER INTO THE CLOSING POSITION. DOING SO RISKS DAMAGE TO THE STRIKE PLATE AND THE LOCK.**

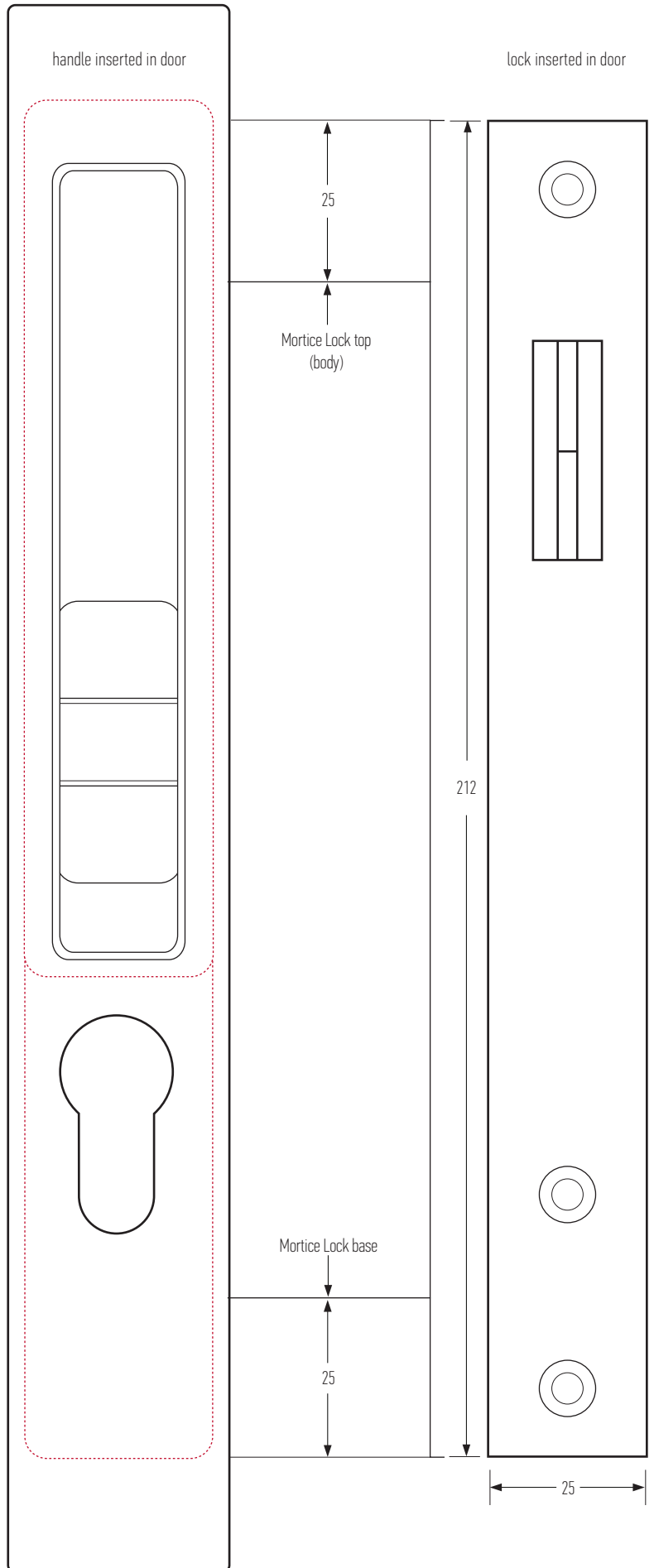

Designed and manufactured in New Zealand. For more information, installation templates, and measured drawings of this product and others please visit : www.hallidaybaillie.com or contact your authorized Halliday + Baillie dealer. All information subject to change.