

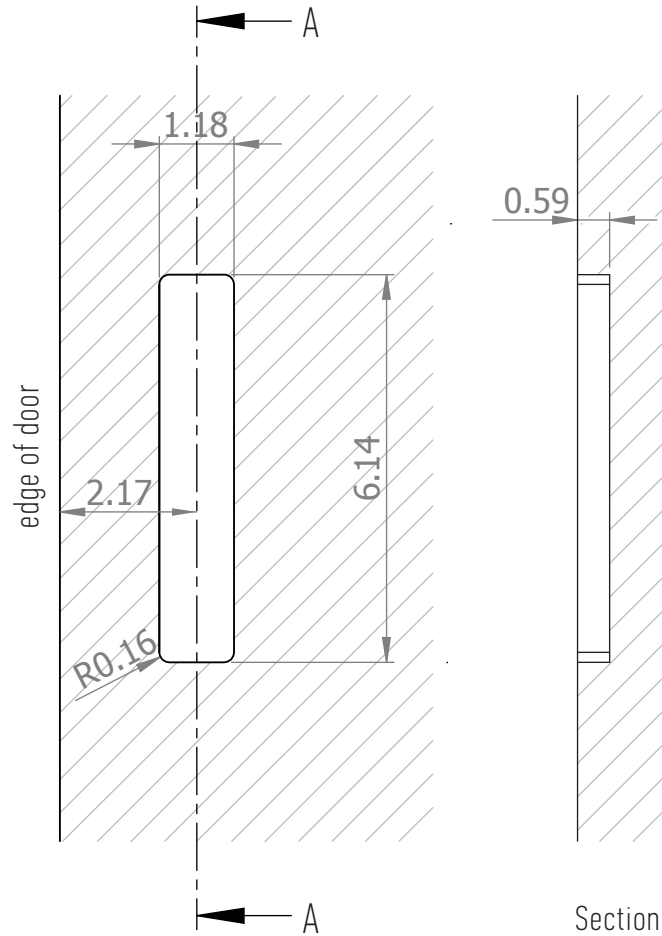

Milling Drawing for timber doors with fixing kits

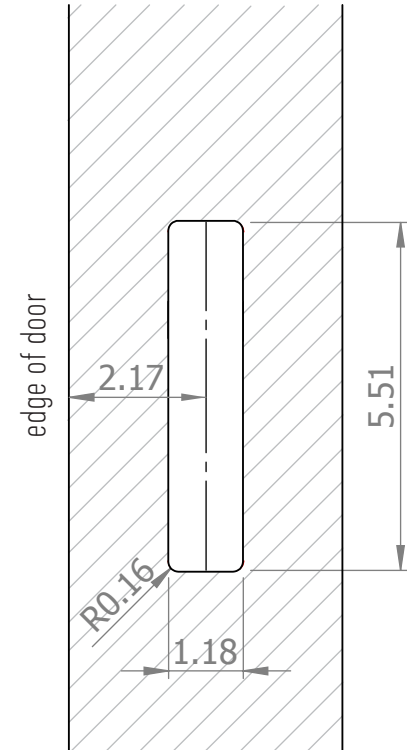

Milling Drawing for aluminium doors



HB 660 - 170mm Flush Pull
Milling Information for HB 660

Drawings not to scale, all dimensions in inches.

Designed and manufactured in New Zealand. For more information, installation templates, and measured drawings of this product and others please visit : www.hallidaybaillie.com or contact your authorized Halliday + Baillie dealer. All information subject to change.